

1520-1590 THE ALAMEDA, SAN JOSE, CA

GARDEN ALAMEDA

±577 - ±6,457 SF OFFICE SUITES FOR LEASE
PREMIER LOCATION | MOVE-IN READY OPTIONS



A CONNECTED OFFICE CAMPUS ON THE ALAMEDA

FLEXIBLE SUITES

WALKABLE AMENITIES

EXCEPTIONAL ACCESS

Garden Alameda is a six-building, ±150,000 SF office campus positioned along San Jose's highly walkable Alameda corridor. The project delivers a professional, modern work environment with upgraded common areas, countless outdoor seating areas, and water features that create an serene campus feel. Tenants benefit from immediate access to a deep retail amenity base, short bike ride times to Diridon Station, and a strong mix of **move-in ready suites** ranging from ±577-±6,457 SF. Garden Alameda is ideal for teams prioritizing convenience, connectivity, and operational efficiency.

- + Move-in ready suites from ±577 - ±6,457 SF
- + Expansive outdoor common areas & collaboration zones
- + ±150,000 SF across six freestanding office buildings
- + Comcast & AT&T fiber connectivity
- + 4/1,000 parking ratio
- + Immediate access to HWY 880, 280, 87
- + Minutes to SJC Airport, offering unmatched connectivity.
- + Walk to: Whole Foods, Crema Coffee, LUNA Mexican Kitchen, and More!
- + T-T Deli on-site & open daily (1520 The Alameda Ste #105)
- + Flexible layouts designed for efficiency

CURRENT AVAILABILITIES

ADDRESS	SUITE	SQUARE FEET
1530 THE ALAMEDA	SUITE 200	±1,460 SF
1550 THE ALAMEDA	SUITE 105	±1,654 SF
1550 THE ALAMEDA	SUITE 200	±2,713 SF
1550 THE ALAMEDA	SUITE 201	±2,049 SF
1550 THE ALAMEDA	SUITE 302	±1,563 SF
1550 THE ALAMEDA	SUITE 305	±1,834 SF
1550 THE ALAMEDA	SUITE 310	±1,377 SF
1550 THE ALAMEDA	SUITE 332	±2,257 SF
1570 THE ALAMEDA	SUITE 215	±1,593 SF
1570 THE ALAMEDA	SUITE 221	±947 SF
1570 THE ALAMEDA	SUITE 316	±2,527 - 6,144 SF



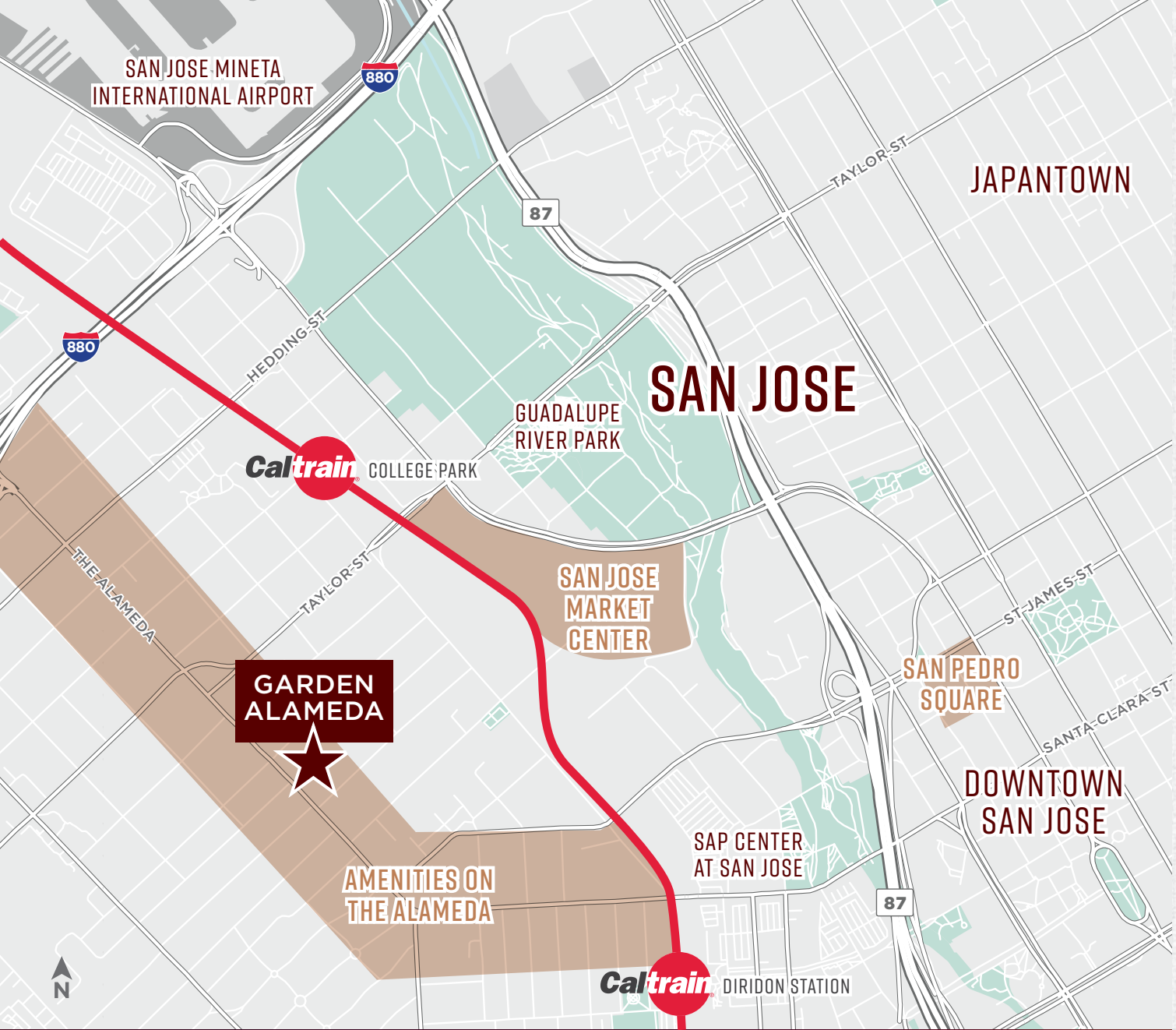

GARDEN ALAMEDA

AMENITIES ON THE ALAMEDA

- ANYTIME FITNESS
- CAFE ROSALENA
- CHIPOTLE MEXICAN GRILL
- CHINA INN
- CREMA COFFEE ROASTING CO.
- FIVE GUYS
- FLOODCRAFT BREWING CO.
- GREENLEE'S BAKERY
- HANNAH COFFEE
- HOP & VINE
- LUNA MEXICAN KITCHEN
- MEDALLO RESTAURANT
- PAPA JOHN'S PIZZA
- PEET'S COFFEE
- ROSIE'S NEW YORK PIZZA
- SUBWAY
- THE UPS STORE
- UNCLE JOHN'S PANCAKE HOUSE
- UPSHIFT CYCLES
- WHOLE FOODS MARKET
- ZONA ROSA

SAN PEDRO SQUARE

- ALMA TEQUILERIA
- ANCHORS FISH & CHIPS
- GAMEDAY
- THE GELATO SHOP
- HELLA GOOD BURGER
- ID CAFE
- LOTERIA TACO BAR
- MARKET BEER CO.
- MARUWU SEICHA
- MASTER SHIN KOREAN PLATE
- MOCHINUT
- ON A ROLL
- PASTA FRESCA
- PIZZA BOCCA LUPO
- PHONOMENAL NOODLE HOUSE
- PLAYBACK COFFEE CO.
- SAN PEDRO SQUARE MARKET BAR
- SUERTE EATERY
- THREE SISTERS WHISKEY BAR
- URBAN MOMO
- URBAN RITUAL

SAN JOSE MARKET CENTER

- BJ'S RESTAURANT
- BLUE MANGO
- CHASE BANK
- EL POLLO LOCO
- GAMESTOP
- HAPPY LEMON
- JAMBA
- L&L HAWAIIAN BARBECUE
- MARSHALLS
- MICHAELS
- PANDA EXPRESS
- PANERA BREAD
- PETSMART
- SALLY BEAUTY
- SMASHBURGER
- SPROUTS FARMERS MARKET
- STARBUCKS
- TARGET
- TRADER JOE'S
- UPS
- WELLS FARGO BANK
- WEST COAST SOURDOUGH
- WORLD MARKET

NEARBY AMENITIES



UNBEATABLE ACCESS



8 MIN BIKE RIDE
TO SAN JOSE DIRIDON STATION

7 MIN DRIVE
TO SJC AIRPORT

35 MIN DRIVE
TO SFO AIRPORT

2 MIN DRIVE
TO I-880



1530 THE ALAMEDA

GARDEN ALAMEDA

SUITE 200 | ±1,460 SF

- + Lobby
- + 4 Offices
- + 1 Conference Room

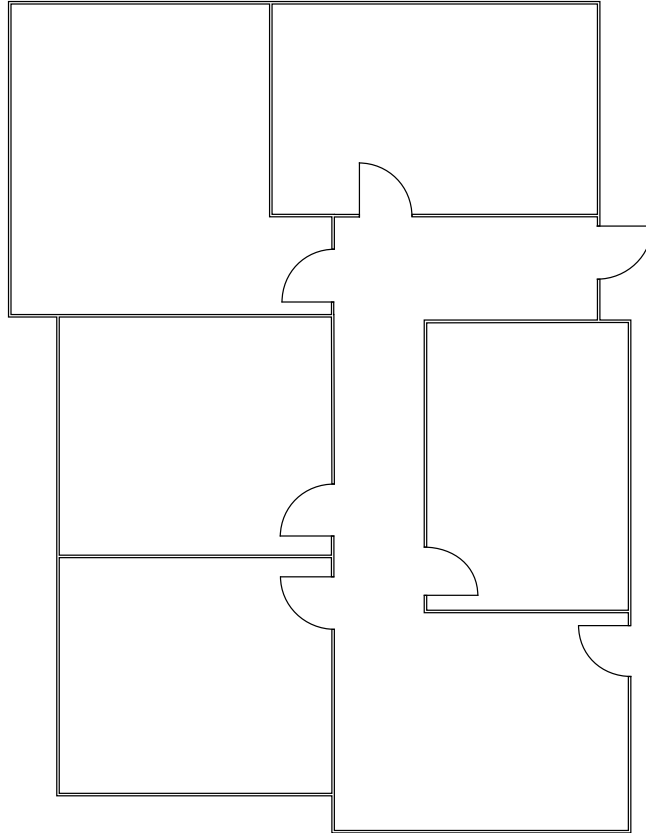

1550 THE ALAMEDA

SUITE 105 | ±1,654 SF

- + Lobby
- + 3 Offices
- + 1 Conference Room
- + Kitchen
- + IT/Server Room

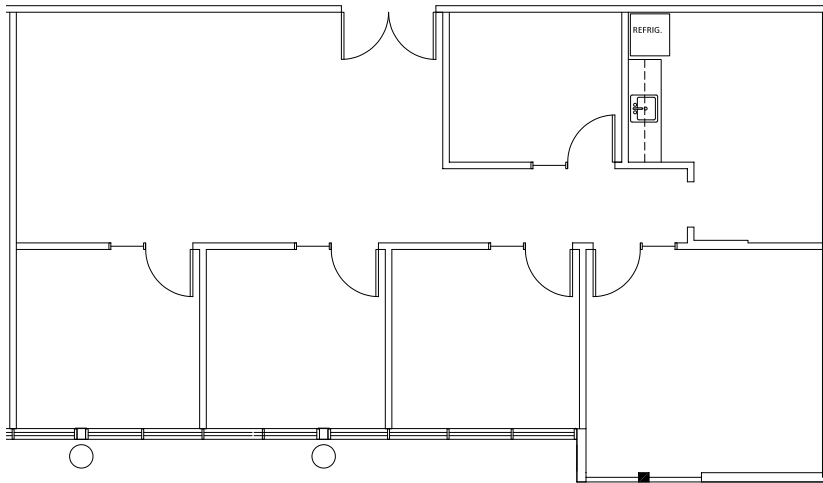

SUITE 200 | ±2,713 SF

- + Lobby
- + 5 Offices
- + 1 Conference Room
- + 1 Kitchen
- + Break Room
- + IT/Server Room

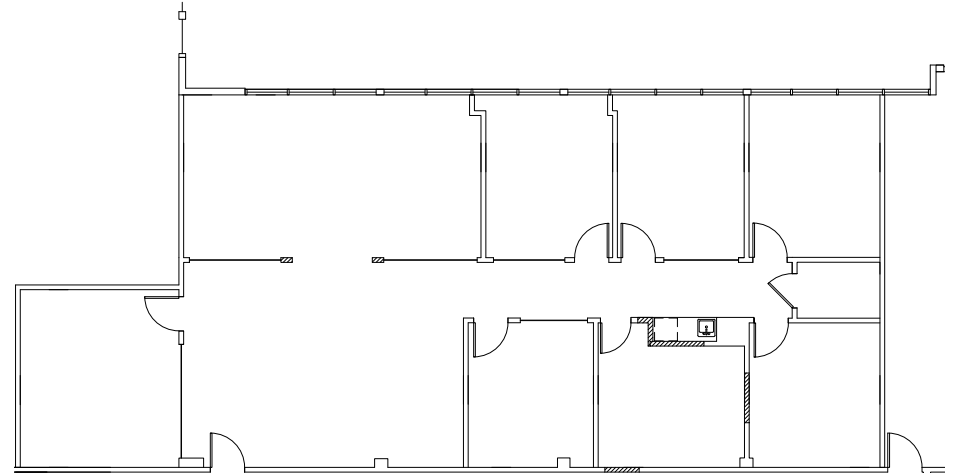

1550 THE ALAMEDA

SUITE 201 | ±2,049 SF

- + Lobby
- + 3 Offices
- + 2 Conference Rooms
- + Kitchen

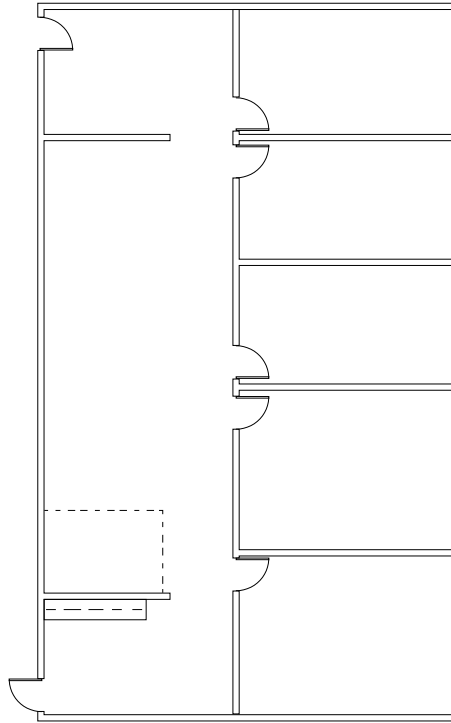

SUITE 302 | ±1,561 SF

- + Lobby
- + 2 Offices
- + 1 Conference Room
- + IT/Server Room

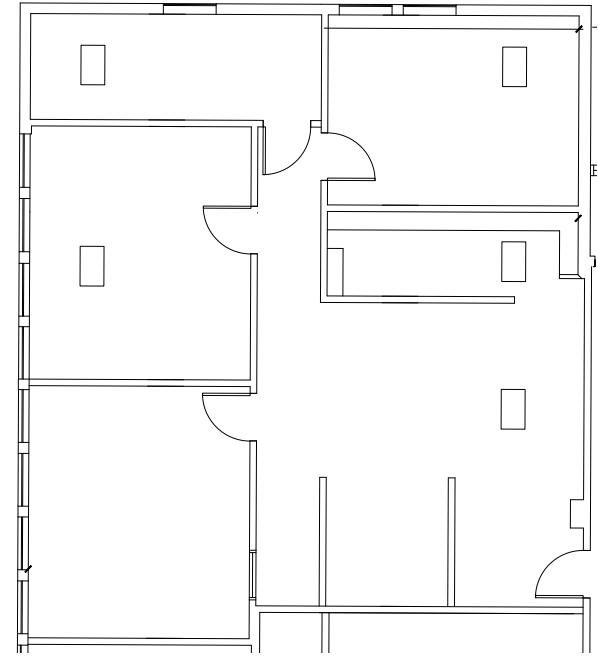

1550 THE ALAMEDA

SUITE 305 | ±1,834 SF

- + Lobby
- + 4 Offices
- + 1 Conference Room
- + Open Office
- + IT/Server Room

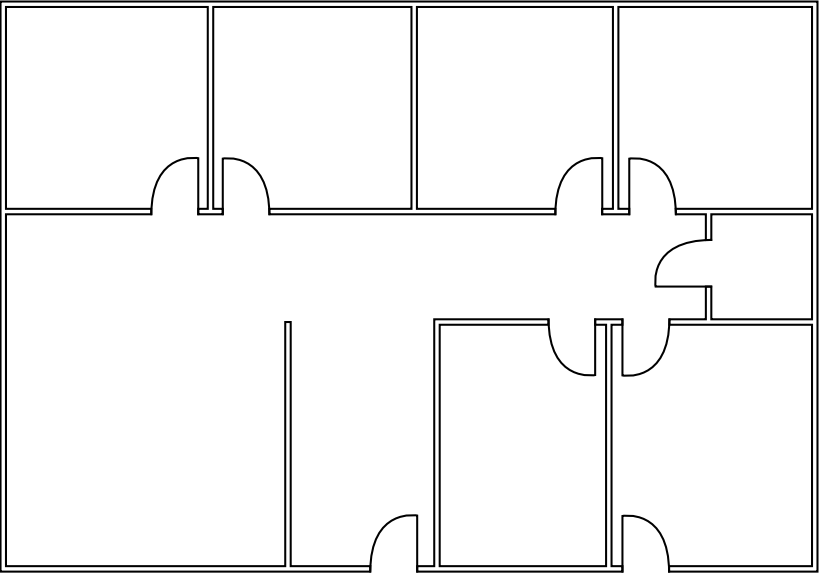

SUITE 310 | ±1,377 SF

- + Lobby
- + 1 Office
- + 1 Conference Room
- + Open Office

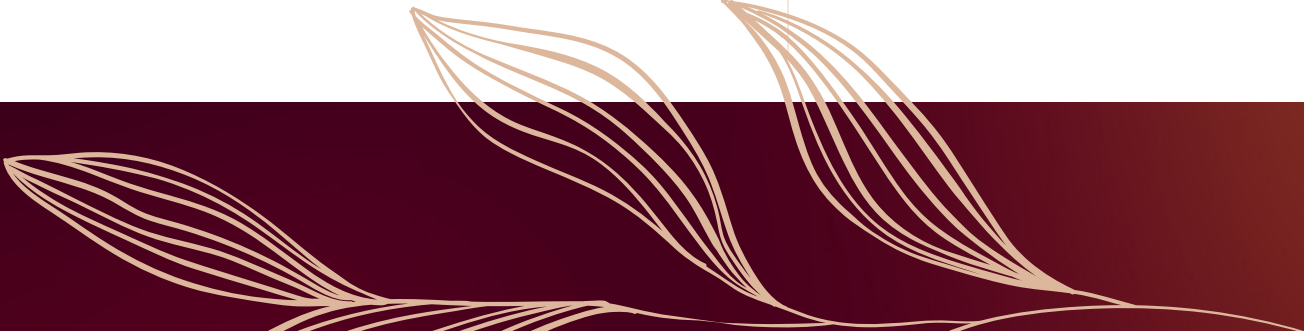
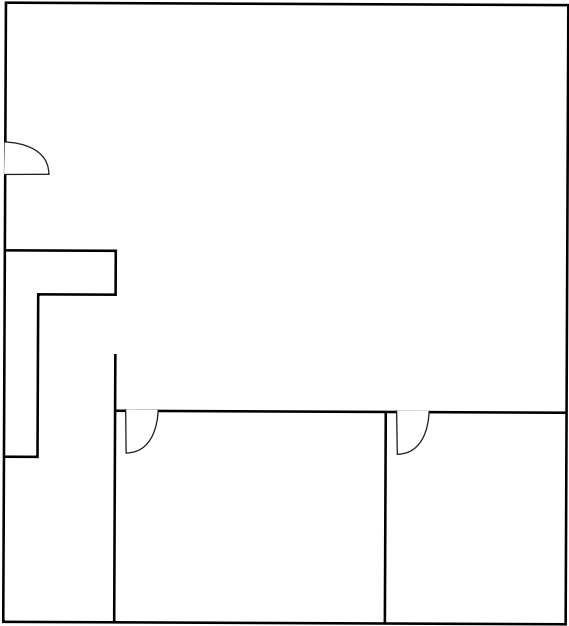

1550 THE ALAMEDA

GARDEN ALAMEDA

SUITE 332 | ±2,257 SF

AVAILABLE: MARCH 01, 2026

- + Lobby
- + 5 Offices
- + 1 Conference Room
- + Break Room
- + Server Room
- + Open Office

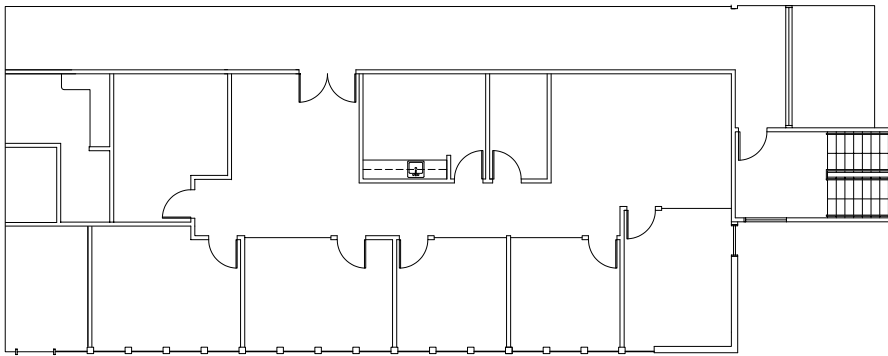

1570 THE ALAMEDA

SUITE 215 | ±1,593 SF

- + Lobby
- + 2 Offices
- + 1 Conference Room
- + Open Office
- + Kitchen
- + IT/Server Room

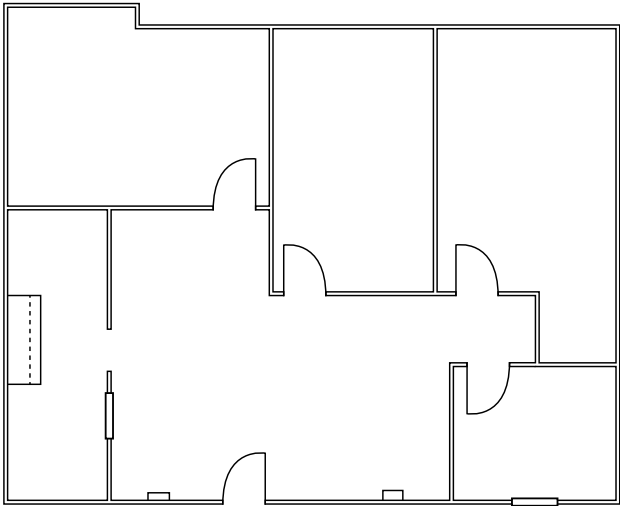

SUITE 221 | ±947 SF

- + Lobby
- + 2 Offices
- + 1 Conference Room
- + 1 Kitchen
- + IT/Server Room

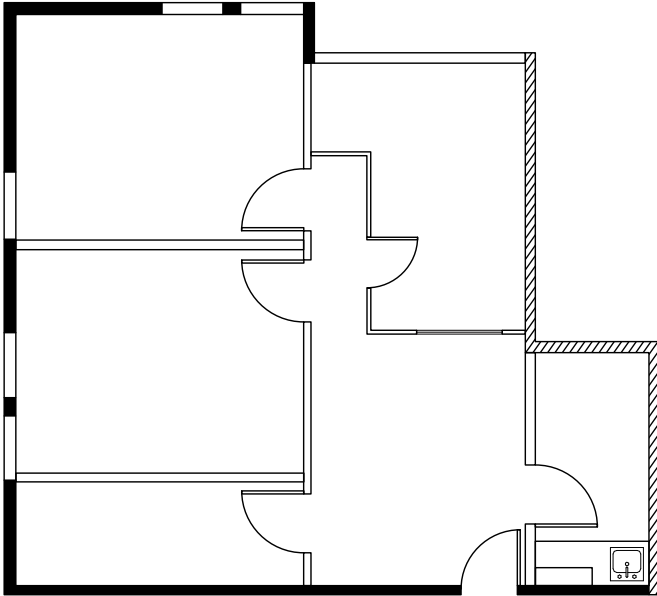

1570 THE ALAMEDA

SUITE 316 | ±2,527 - 6,144 SF

AVAILABLE NOW

- + Market Ready!
- + Lobby
- + 6 Offices
- + 2 Conference Rooms
- + Server/IT
- + Open Kitchen & Break Area
- + Open Office

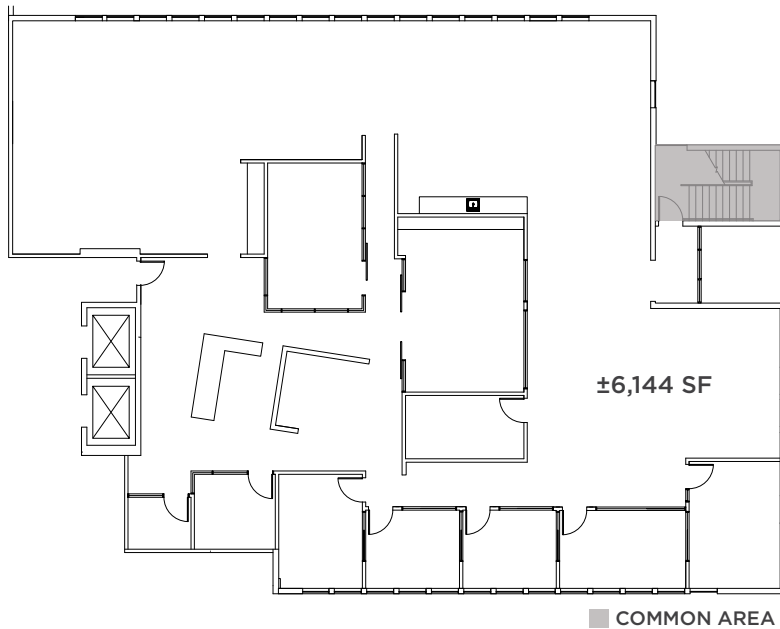

HYPOTHETICAL DEMISING PLAN

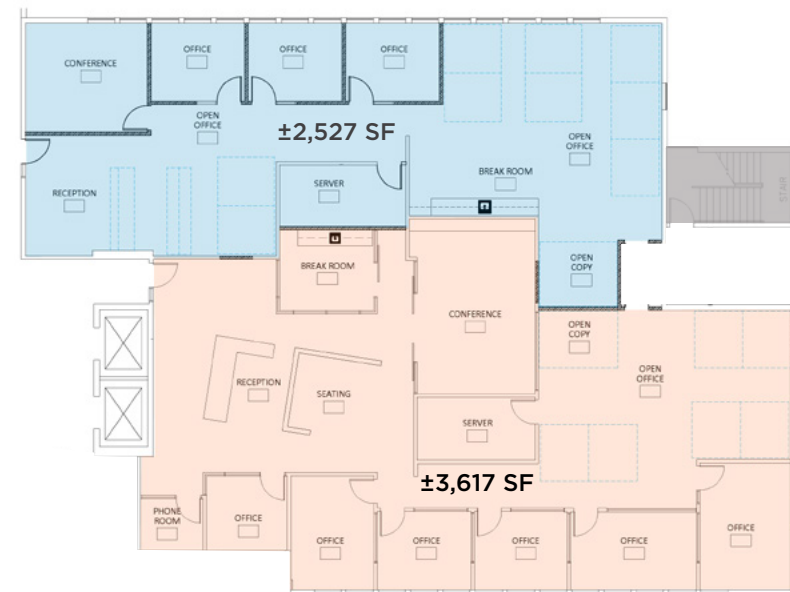

ERIK HALLGRIMSON

+1 408 615 3435

erik.hallgrimson@cushwake.com

LIC #01274540

KATE MYERS

+1 408 502 0196

kate.myers@cushwake.com

LIC #02253804

GARDEN ALAMEDA



©2026 Cushman & Wakefield. All rights reserved. The information contained in this communication is strictly confidential. This information has been obtained from sources believed to be reliable but has not been verified. NO WARRANTY OR REPRESENTATION, EXPRESS OR IMPLIED, IS MADE AS TO THE CONDITION OF THE PROPERTY (OR PROPERTIES) REFERENCED HEREIN OR AS TO THE ACCURACY OR COMPLETENESS OF THE INFORMATION CONTAINED HEREIN, AND SAME IS SUBMITTED SUBJECT TO ERRORS, OMISSIONS, CHANGE OF PRICE, RENTAL OR OTHER CONDITIONS, WITHDRAWAL WITHOUT NOTICE, AND TO ANY SPECIAL LISTING CONDITIONS IMPOSED BY THE PROPERTY OWNER(S). ANY PROJECTIONS, OPINIONS OR ESTIMATES ARE SUBJECT TO UNCERTAINTY AND DO NOT SIGNIFY CURRENT OR FUTURE PROPERTY PERFORMANCE. COE-PM-West-03.11.2026